



Application

Contec COMS (Contec Oil Mist Separators) for the extraction and filtration of oil mist are used for large-scale compressors, gas and steam turbines, generators and other equipment with oil systems to ensure clean, oil-free exhaust air. 99.98% of solid and liquid particles and aerosols down to 0.1 micron are removed and high-quality oil can be regained. The COMS high-efficiency filter system prevent the emission of oil mist into the atmosphere and therefore guarantee oil-free technically absolutely clean exhaust air. Additionally due to the coalescing effect high-quality lubrication oil including all its additives is regained and recycled into the process.

Material

Housing	<ul style="list-style-type: none"> • Steel S235JR, fully galvanized, outside painted or • Stainless steel 316/316L, glass bead blasted or painted • Internal parts aluminium, no brass or copper or out of stainless steel
----------------	---

General specification

Housing	Ø 500 x 1.261 mm
Pillar tube	300 mm
Dimensions	1.300 x 606 x 1.598 mm (L x B x H)
Inlet flange	DN 100 PN 16 or 4" ANSI 150 lbs RF
Exhaust	4" pipe socket with IG, DN 100 PN 16 or 3" ANSI 150 lbs RF
Weight	ca. 280 kg
Operation pressure	max. -0,2 to 0 bar
Operation tem.	max. 60 °C



Filter elements

Glass fibre fleece with inorganic binder	
Type	COMS-5500-XL-50
Quantity	13 off
Separation degree	99,98 % at 0,1 droplet size, Residual oil content < 0,1 mg/m ³ *

* tested by the Institute of Energy and Environmental Technology e. V. (IUTA) in Duisburg in accordance with ISO 12500-1:2007e

E-Motor

Power	4,0 kW
Voltage	230/400 V, 50 Hz
IP rating	IP 55

Available as "G"-series with foreign motor acc. specification

Side channel blower

Sound Pressure Level	77 dB(A) at 50 Hz
Flow rate	600 Nm ³ /h at -60 mbar Δp 50 Hz 750 Nm ³ /h at -60 mbar Δp 60 Hz

Scope of supply

The CONTEC-Oil Mist Separator are supplied fully assembled and ready for installation including:

- One set of filter elements
- Negative pressure gauge
- Hand ball valve for negative pressure control
- Air suction filter
- Oil sight flow glass

Options

- Ex/ATEX
- Redundant series (2 x 100 %)
- Integrated bypass
- Recirculator
- Series without motor/blower unit
- Adapter flange tube for inner oil return flow



Oil Mist Separator type 5500/762

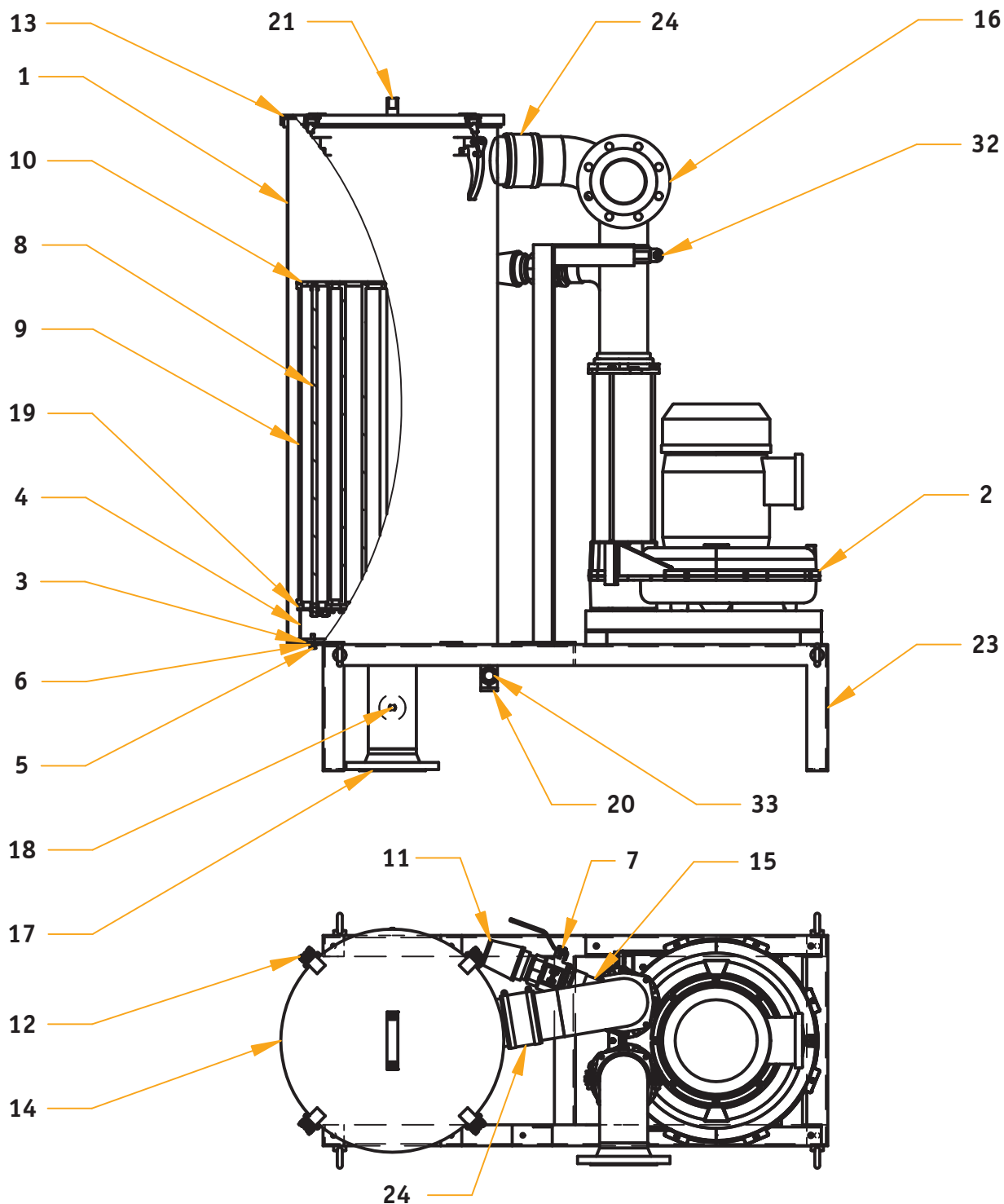

The installation

- | | | |
|------------------------|-----------------------------|---------------------------|
| 1. Housing | 12. Catch | 23. Base Frame |
| 2. Side channel blower | 13. O-Ring | 24. Compensator |
| 3. O-Ring | 14. Housing Cover | 25. --- |
| 4. Filter base | 15. Inlet T-Piece | 26. --- |
| 5. Fastening Screw | 16. Exhaust | 27. --- |
| 6. Seal | 17. Pillar Tube with Flange | 28. --- |
| 7. Hand Valve | 18. Negative Pressure Gauge | 29. --- |
| 8. Tie Rod | 19. Filter Element Base | 30. --- |
| 9. Filter element | 20. Oil Drain Connection | 31. --- |
| 10. Retaining Cap | 21. Lifting Handle | 32. Pipe Clamps |
| 11. Air-Suction-Filter | 22. --- | 33. Oil drain sight glass |